



Typ / Type : ERND 200-2 (LG/RD)		Art.-No. : B15-20020 / B15-20021	
U	400V (50Hz)	$\Delta p_{fa \text{ min}}$	1090 Pa
P ₂	2.2 kW	ΔI	-- %
I _N	4.61 A	I _A / I _N	6.1
n	2840 min ⁻¹		IP55
C _{400V}	-- μ F		01.430
t _R	40 °C		26 kg

Geräusche / Sound levels:

LWA _{rel} A-bewertet bei V=0,5*V _{max} LWA _{rel} A-weighted at V=0,5*V _{max}	fM [Hz]						
	125	250	500	1K	2K	4K	8K
Ausblasseite 4-polig / outlet side 4-pole	-23	-10	-8	-4	-7	-9	-16
Ansaugseite 4-polig / inlet side 4-pole	-19	-11	-11	-5	-5	-8	-14
Ausblasseite 6-polig / outlet side 6-pole	-23	-10	-6	-6	-6	-8	-15
Ansaugseite 6-polig / inlet side 6-pole	-20	-18	-8	-5	-5	-8	-16

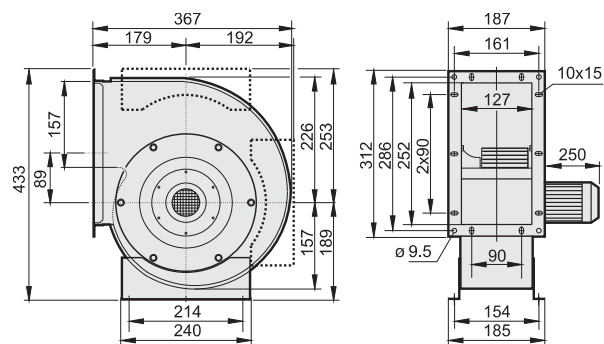

Zubehör / Accessories: